



A plan that moves people & takes cars off roads!

**Reduce air quality
problems!**

ROAM Transport Systems, Fort Worth, Texas

SuperWay, MegaWay, CargoWay, MicroWay, CarLiner, CarFerry, SkyCoach, CargoLiner, WhisperLiner, MegaLiner, & PersonLiner are trademarks of ROAM Transport Systems

U.S. PATS. 6,039,135, 6,401,625, 6,435,100, 6,615,740, 6,742,458, 6,834,595, 6,837,167, & 7,926,425 B2

OTHER U.S. & INTERNATIONAL PATENTS PENDING

ROAM® is a registered trademark of XIP, LLC licensed to ROAM Transport Systems

© Reg. U.S. Pat. & Tm. Off.

ROAM graphics & photos

5-28-15

User & Taxpayer Wants

USERS

- Drive my own car non-stop to destination!
- Stop trying to get me out of my car
- Avoid traffic delays and accidents

TAXPAYERS

- Don't raise my taxes!
- Fix the problem ASAP
- Reduce pollution!

Rail systems *can't do it!*

Difficult to use Freight Railways

Most railroad lines – **At capacity with freight**

New right of way – **almost impossible to obtain**

Railroads **reluctant to accept** passenger trains

- Most lines far below passenger standards – High upgrade cost
- Railroads want liability protection – **“Freight never sues”**

Ultralight Commuter *MegaWay CarLiner*TM

Fast service in your car or in train coach at low cost



Ultralight *MegaWay* commuter *CarLiner* on elevated *SuperWay*

*SkyCoach*TM & *CarFerries*TM in single train

Automobile passengers never leave their car for commute!

High Performance

High-speed – 85-mph – For short trip times!

- People travel in their cars – Few in train coaches!
- High line capacity – With full dual-track system
 - Up to 3,570 automobiles pphpd (400-ft stations & 16-car trains)
Plus up to 2,856 pphpd in train coaches
- Off-line stations for both local and express trains

Grade-separated – Small, factory-built steel *SuperWays*

Go-anywhere (**including up hills**) – Cars use rubber tires

Cost less than driving the same distance!

Freeway to *SuperWay* Shift

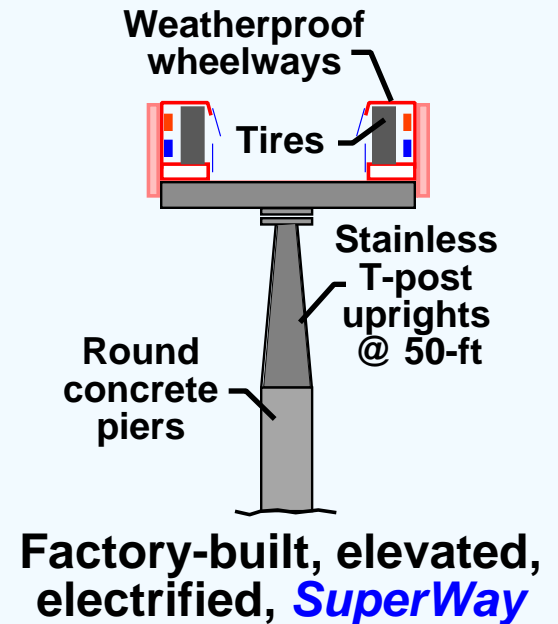
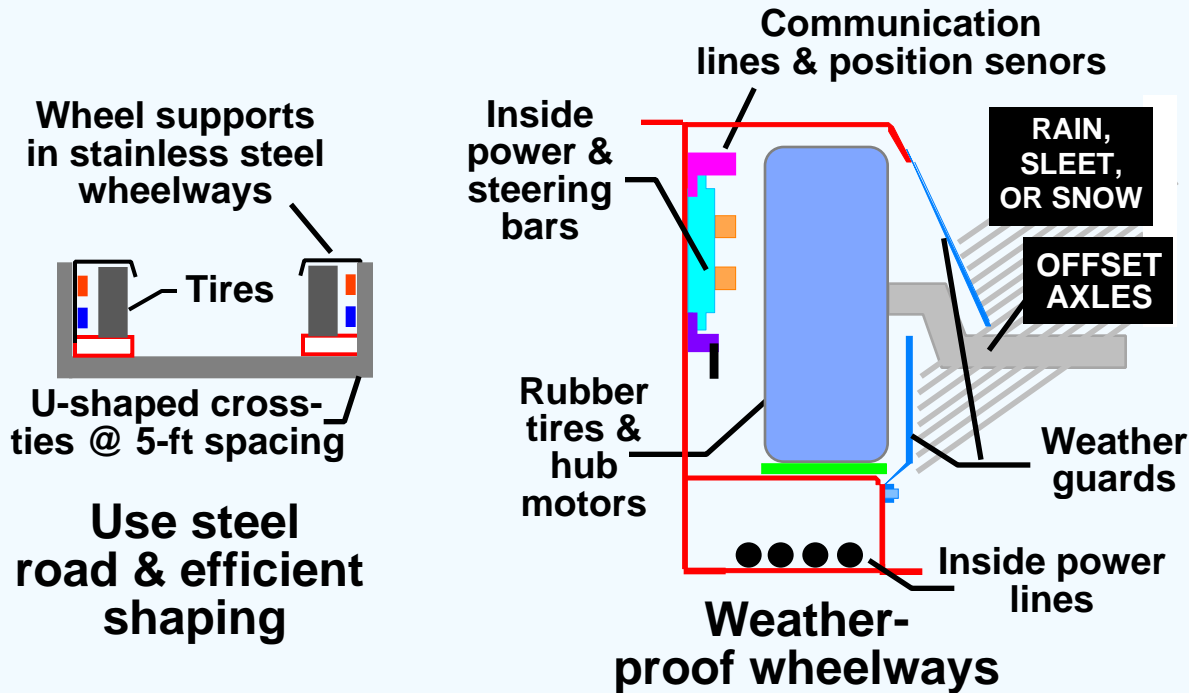
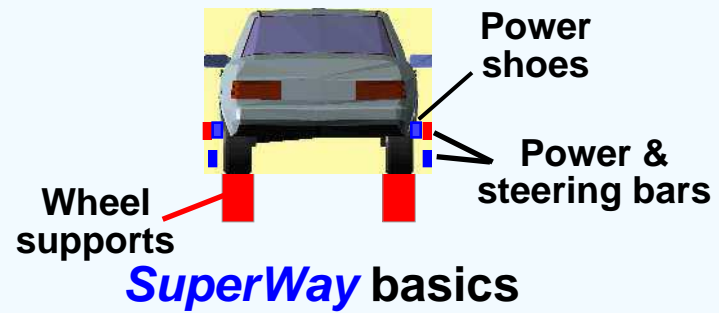
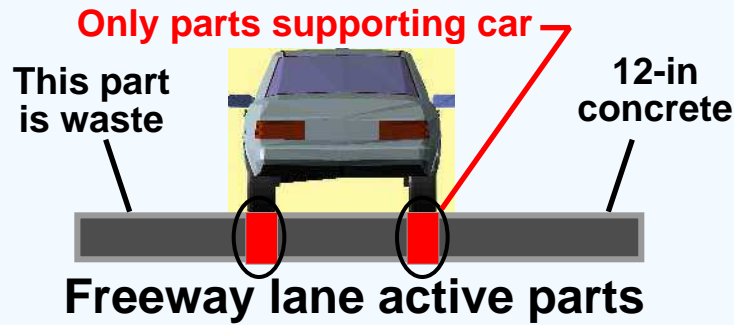

Low-cost, electrified, automated super-freeway

CarFerries™ allow people to *take their cars*

Rapid (1-min) loading and unloading by car drivers at stations

CarFerries provide fast Load & Unload

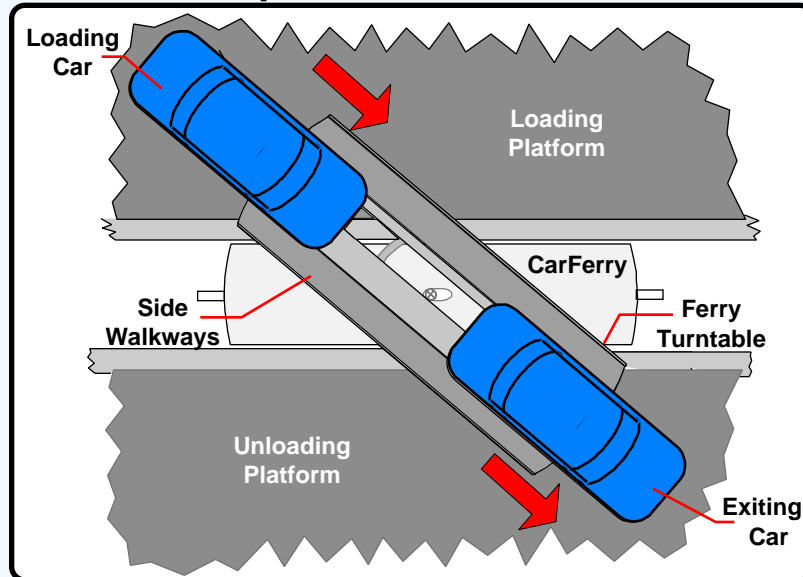

Car drivers drive their cars onto and off of ferries at stations

Easy as pulling into slant parking space or car wash

Car wheels automatically locked into place on ferry to hold car

- People in cars that need their cars
- People in *Skycoaches* who don't need cars

Individual *CarFerry* Safety Features

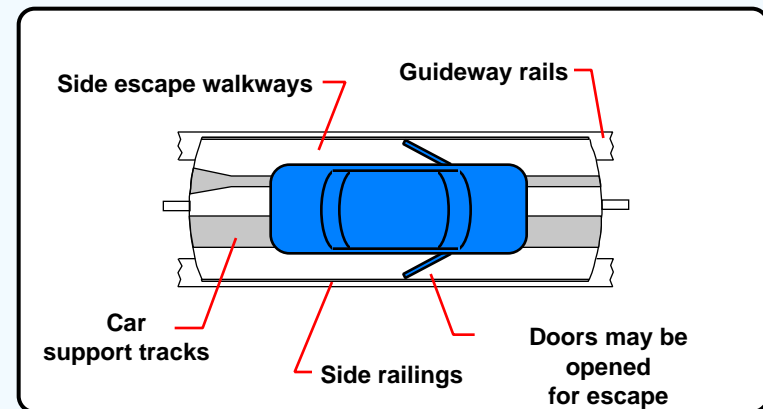

Ferry walkways enable passengers to access *SuperWay* center emergency walkways

Roll correction in curves for airliner ride comfort level

Sample *CarLiner*TM Station Arrangement

Short *Carliner* train shown to simplify illustration

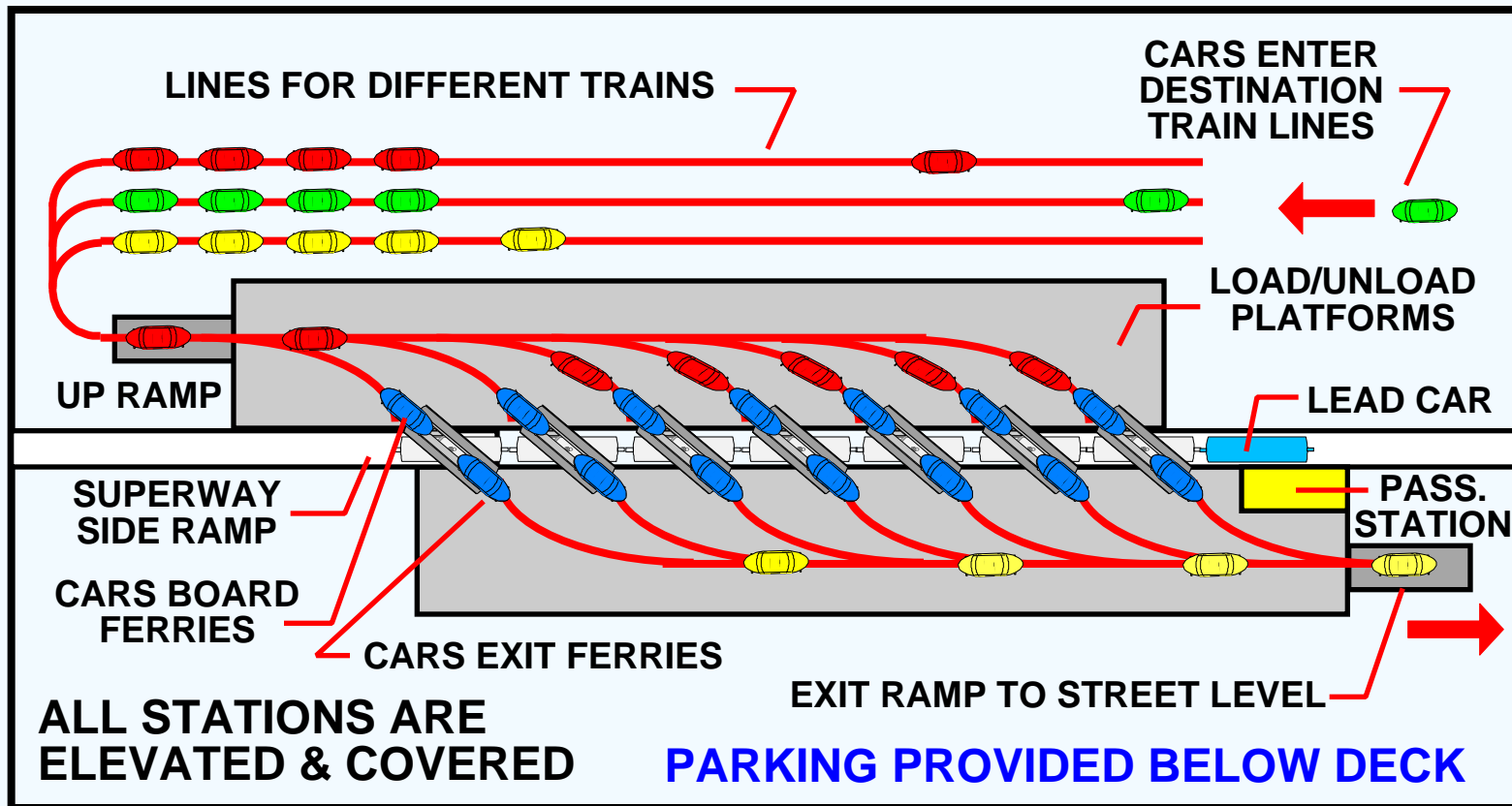

Drivers enter line for desired route or destination
 (Trains may take different *MegaWay* routes)

***SkyCoaches* have Spacious Interiors**

Large, comfortable seats – Wide center aisle

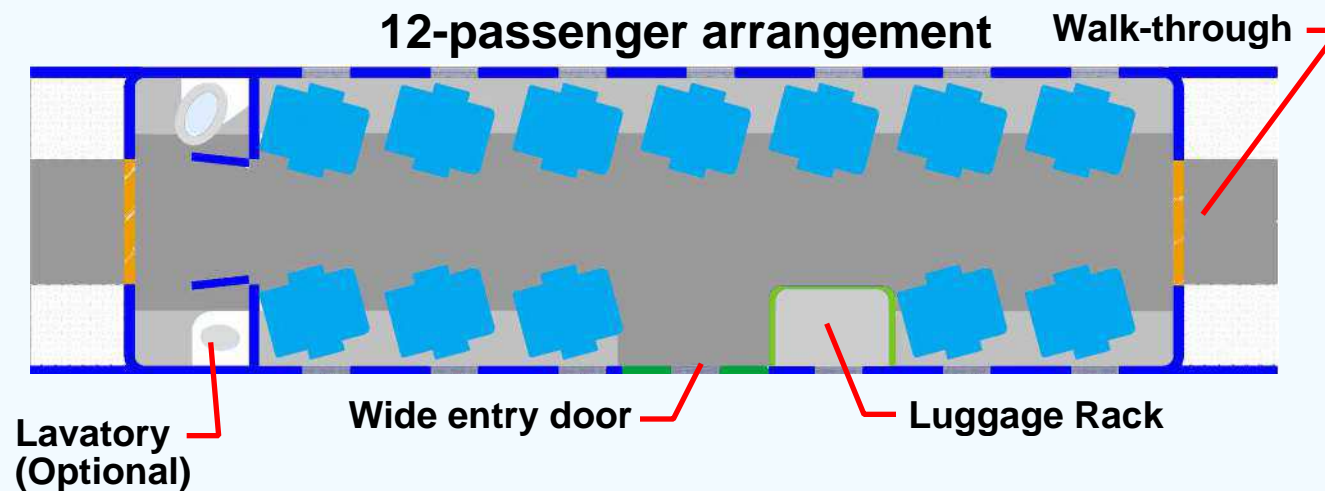

For traditional train passenger use

**Roll correction and banked curves for
airliner ride comfort level**

Prototype Test & Demo Vehicles

Road and *SuperWay* tested

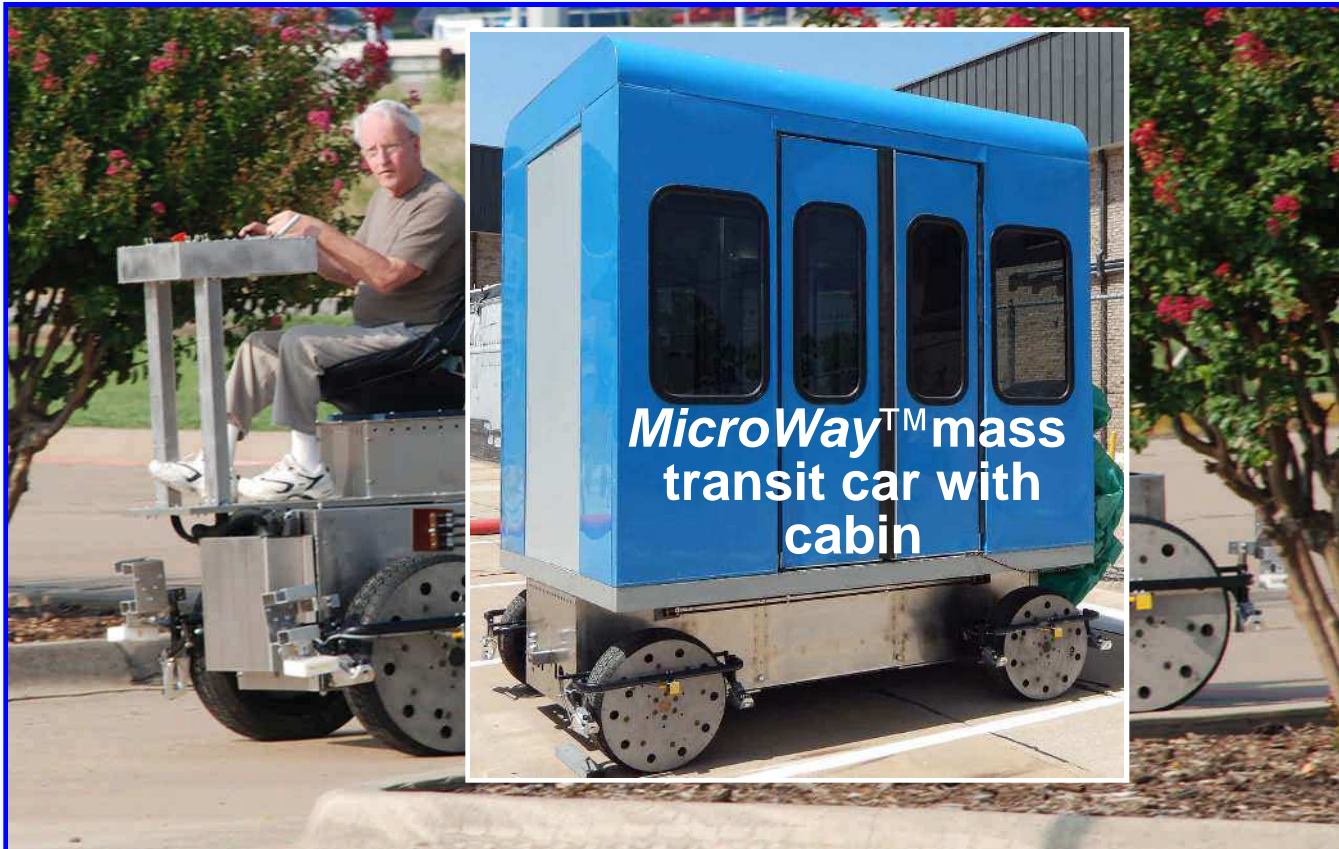

Hybrid dualmode car chassis unit in test & transit demo car
(Dualmode version operates both on *SuperWay* & streets)

Not just a “paper” system – It’s real and here!

Commuter *MegaWay* is Available NOW!

SuperWay installation

- Guideway engineering – Immediate start
- First production guideway sections deliver in 12 months

Train production – (*MicroWay*™ Prototype operating)

- Start within 12 months
- Deliveries within 18 months

First service within 42 months – (Manual control)

No wait for extensive new development!

Small, *Low Cost*, Factory-built *SuperWay*

Fast, bolt in place installation

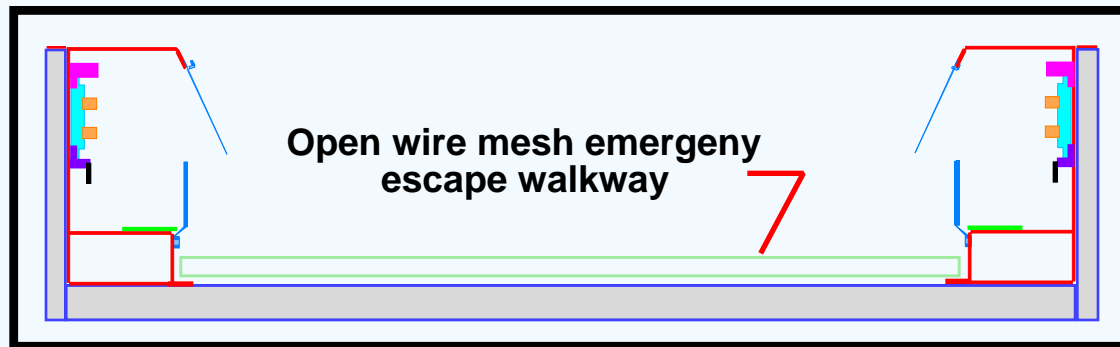

10.5-ft
wide by
40-inch
high
*MegaWay
Superway*

Ultralight *SuperWay* cross-section

Cost — 20% of elevated railway or freeway lane

- Uses highway/street right-of-way
- Mass-produced, factory-built sections – Fast on-site assembly
- No more land used & earth moving projects
- Light weight – Vehicles only 5% of typical railcar or truck weight

Low-cost, All-weather, Enclosed *WheelWays*

- Low-cost *WheelWays*

- Parts cut from flat steel
- Machine-welded construction
- Low material & labor costs
- Bolt-in electric power bars
- Truck guideway sections to site

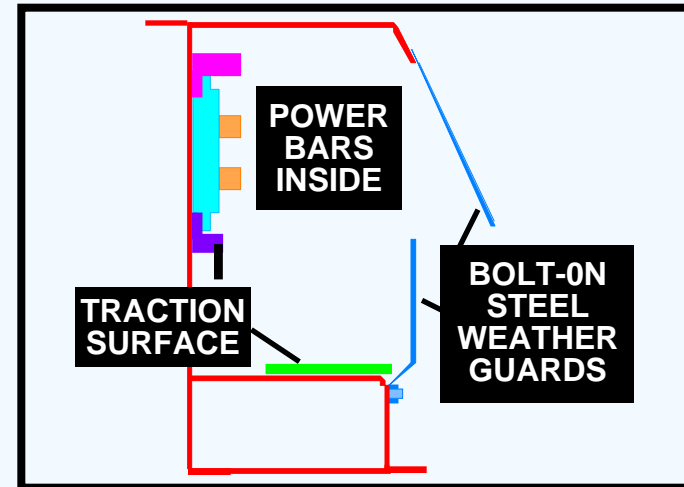

Single wheelway cross-sections

- All-weather, *WheelWays*

- Wheels & power collectors inside
- Protected electric power bars
- Dry & ice-free traction surfaces
- Safe operation in any weather
- Whisper-quiet operation

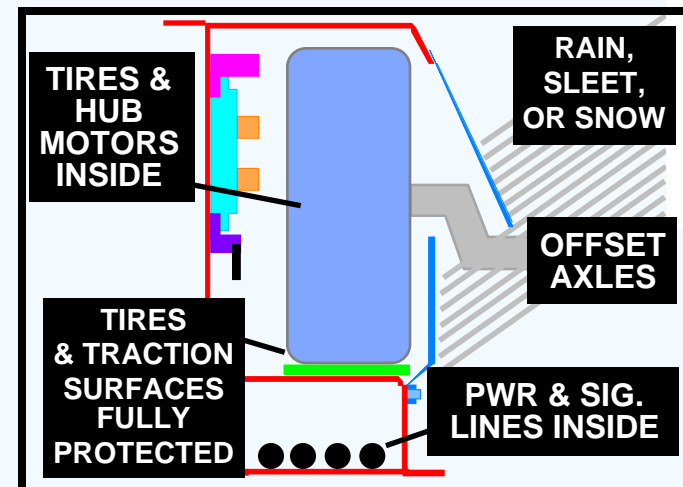

WheelWays & cross-members form self-supporting “U” structure

***SkyCoaches* offer Safe Escape**

Unaided escape for all (including wheelchairs) without rescue personnel



- Full-height escape doors in ends of coaches
- Open-mesh escape walkway between rails
- Covered electric bars



Upward view through walkway

Technology Summary

Unique, patented new combination of proven technology (8 patents)

Enclosed stainless-steel wheelways - US Pat. 6,039,135

- Simple welded steel factory fabrication
- Standard power rails

Flat-free tires – Current technology

Permanent-magnet electric motors

- Current commercial motor technology
- Electric motor wheels – Some electric cars

Car-based steering & switching

- Smooth non-contact electronic steering
- Switching – By cars as on conventional freeway!

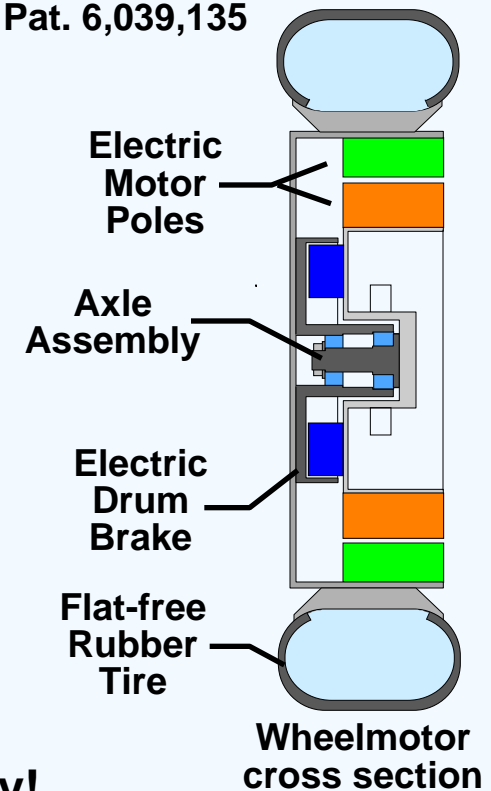

Only the combination & SuperWay are new!

Commuter *MegaWay CarFerry* Summary

Performance – Far superior to any other system

- Seamless commute for automobile users – No last mile problem
- Major reduction in road traffic
- Bus-type hill capability

Start first service – Within 42 months!

- Shorter time than for rail systems - No funding delays

Total system cost – 38% of sample rail plan cost – Single lane

- Local revenue bond funding and control
- No tax subsidies

Environment friendly – Noise free operation

- No construction impacts to business or street traffic
- No earth moving
- Removes cars from freeways!

MegaWay - The 21st Century Commuter Service Available NOW

MegaWay commuter
can rapidly end
air quality problems

Expand to Cross-country **120-mph** Services



Passengers use luxurious *SkyCoaches* for long trips – Cars ride behind

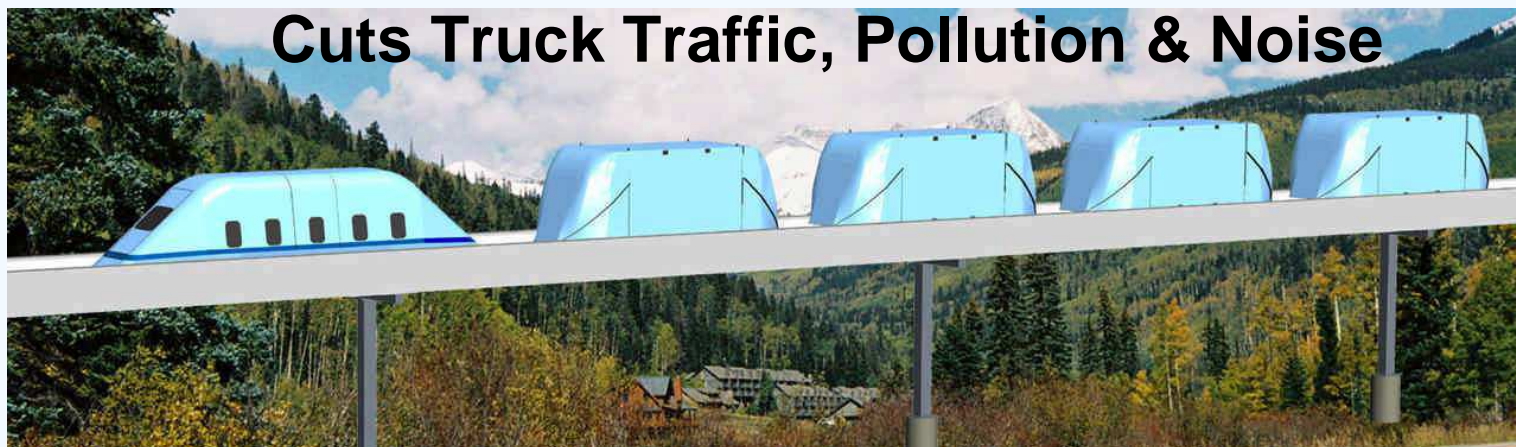

Cargo moves in three-ton containers with low-drag fairings

Future 120-mph, Inter-city Services

U.S. Pat. 6,435,100

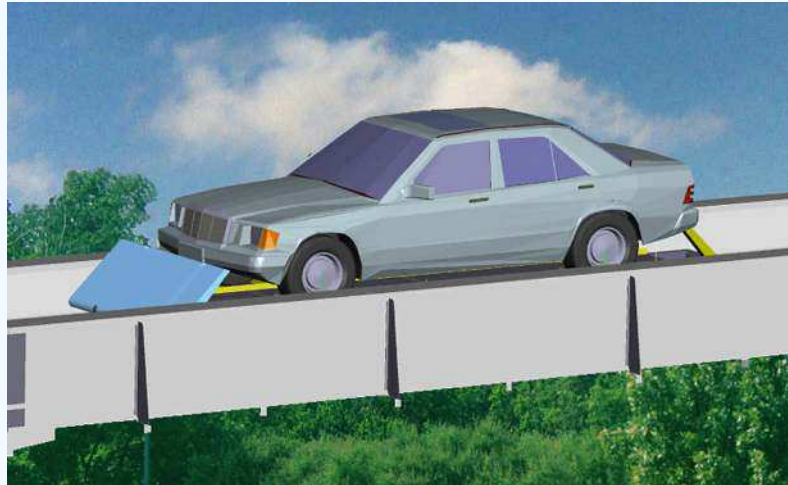

Carferries carry standard cars with driver and passengers inside

U.S. Patent 6,615,740

MegaRail photos & graphics

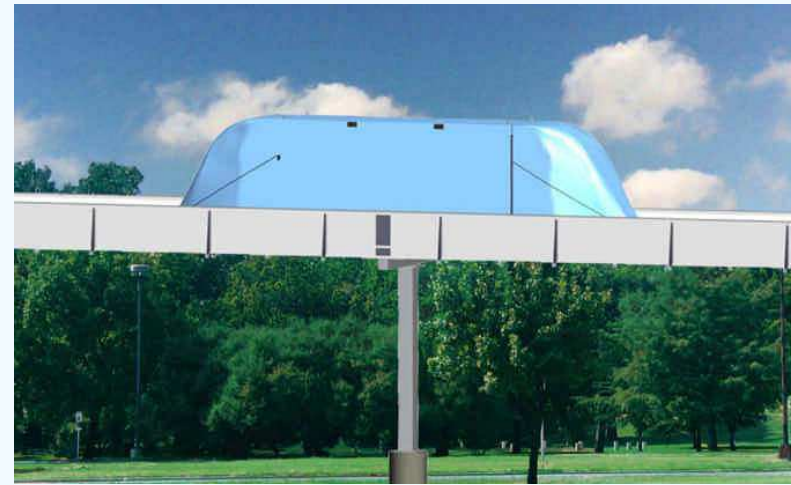

Automated cargo car on *Superway* moves modules at speeds up to 120-mph

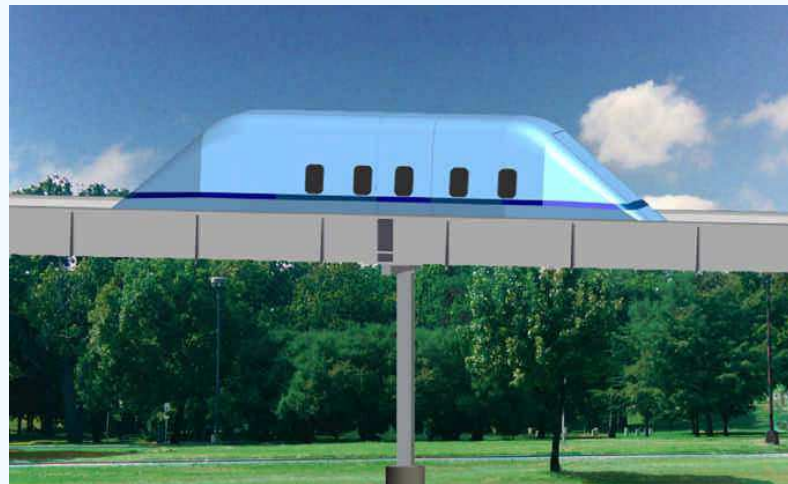

Automated, eight to nine-passenger *MegaLiner*[™] non-stop, 120-mph, high-frequency, 24-hr group service

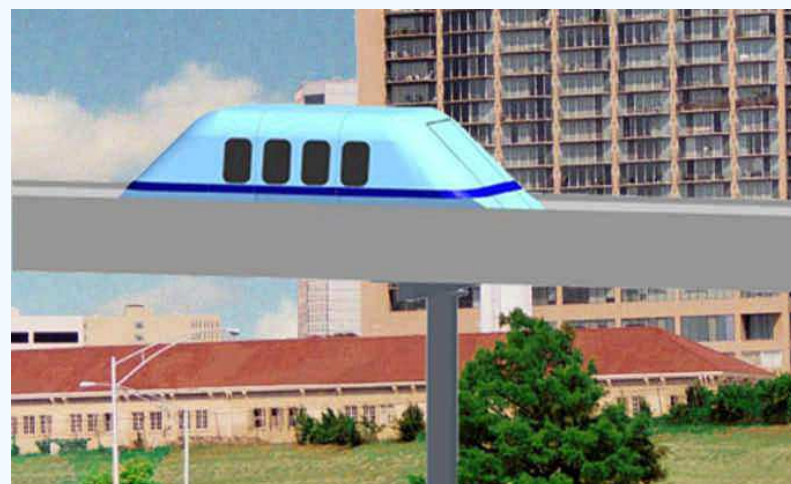

Four to six-passenger *PersonLiner*[™] non-stop, 120-mph, on-call, 24-hr personal service



401 West Jim Wright Freeway, Suite 113

Mail Address

P. O. Box 121728
Fort Worth, Texas 76121

(817) 738-9507

FAX (817) 367-2373

contact@roamtrans.com

www.roamtrans.com

Revolutionary, High-speed, Multi-user
21st Century Transport!

- *Unprecedented* level of service
- Low transportation user costs

**Near-term & affordable solution to
traffic & air pollution problems**

ROAM® Transport Systems, Fort Worth, Texas

SuperWay, MegaWay, CargoWay, MicroWay, CarLiner, CarFerry, SkyCoach, CargoLiner, WhisperLiner, MegaLiner, & PersonLiner are trademarks of ROAM Transport Systems

U.S. PATS. 6,039,135, 6,401,625, 6,435,100, 6,615,740, 6,742,458, 6,834,595, 6,837,167, & 7,926,425 B2

OTHER U.S. & INTERNATIONAL PATENTS PENDING