

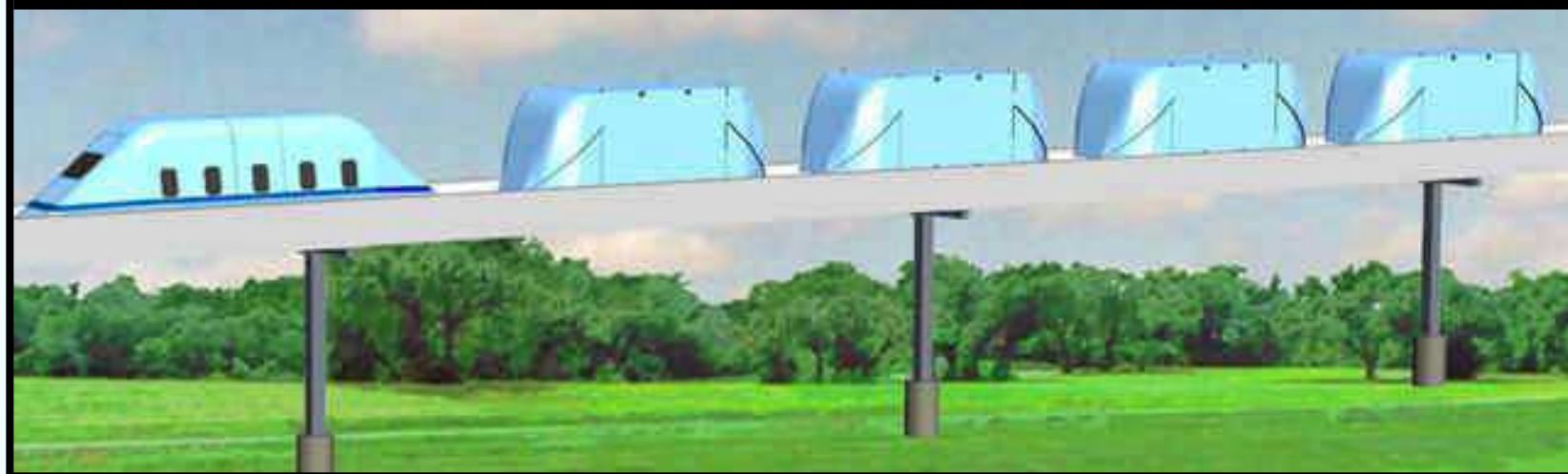

SuperWays™ Solve Freeway & Highway Problems

Moving transport out of the 19th century



ROAM Transport Systems, Fort Worth, Texas

SuperWay, MegaWay, CargoWay, MicroWay, CarLiner, CarFerry, SkyCoach, CargoLiner, WhisperLiner, MegaLiner, & PersonLiner are trademarks of ROAM Transport Systems
 U.S. PATS: 6,039,135, 6,401,625, 6,435,100, 6,615,740, 6,742,458, 6,834,595, 6,837,167, & 7,926,425 B2
 OTHER U.S. & INTERNATIONAL PATENTS PENDING

ROAM graphics & photos

ROAM® is a registered trademark of XIP, LLC licensed to ROAM Transport Systems

© Reg. U.S. Pat. & Tm. Off.

Current Highway Transport Picture

Critical Problems without Easy Solutions

- **Saturated highways**
 - Inadequate funds to build or improve roads
 - Heavy trucks *pulverizing pavement*
- ***Critical* air pollution problems**
 - Unpopular & expensive actions required
- **Passenger rail – almost non-existent**
 - Conventional rail – **Unable to sustain**
 - High-speed & commuter rail – *Far too costly*

Usual options – far too expensive

- Urban light rail & BRT - \$30 to \$60 million/mile - (Houston - \$37 M/mi)
- Rebuild & widen interstates - \$6 million/mile - (TxDot Est. – 2002)
- Urban freeway cost - \$116 million/mile - (TxDoT Est. – 2005)
- Add HOV lanes - \$5 million/mile - (TxDot Est. – 2002)
- Commuter rail (Existent track) - \$24 million/mile - (“T” commuter)
- High-speed rail - \$40 to \$80M/mile - (German [maglev] - \$77M/mile)

**Current & projected budget will cover only
O&M costs.**

New road construction impossible with taxes!

**State and Federal money for any of
the above will be hard to come by.**

***SuperWays* Solve the Problems**

Unified transport approach

- **Decongest Highways**
 - Reduce highway car & most **heavy** truck traffic
 - Carry higher passenger & cargo loads
- **Cut Cost** – **Both low road O&M & new system costs**
 - 20 to 40% of other solutions – **But no taxes!**
 - **10%** of time to provide new service
 - **Eliminate** need for costly high-speed rail!
- **Reduce noise & air pollution**
 - Rubber tires inside enclosed rails
 - *Transport with **natural gas electric power !!!***

Freeway to *SuperWay* Shift

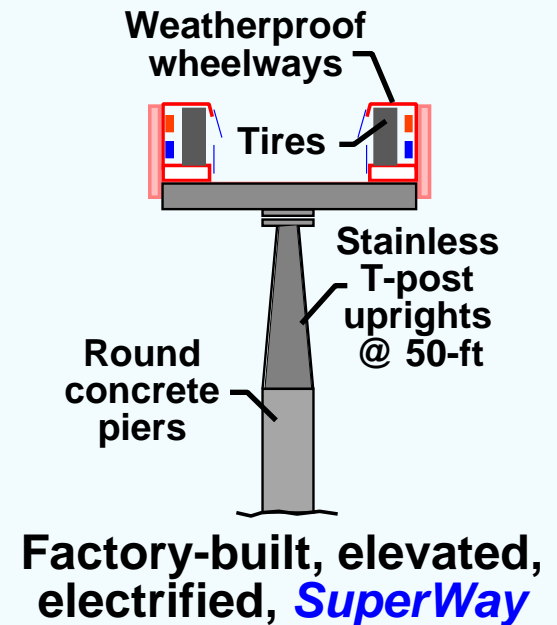
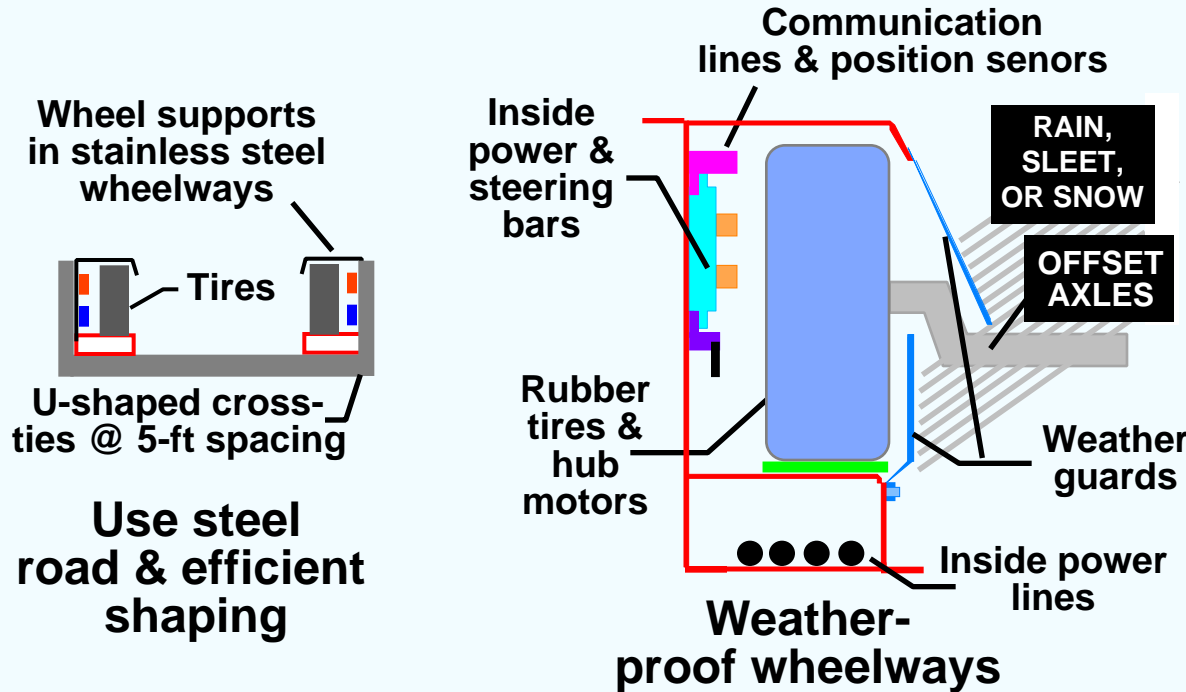
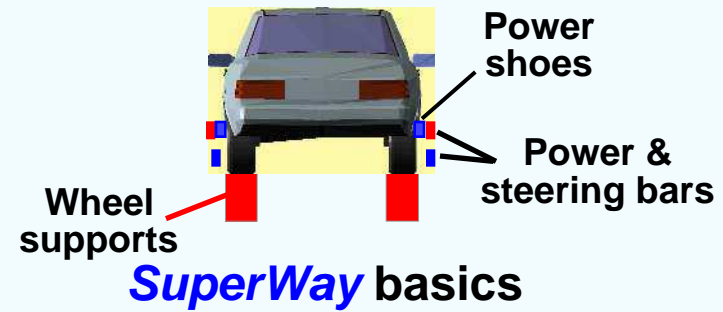
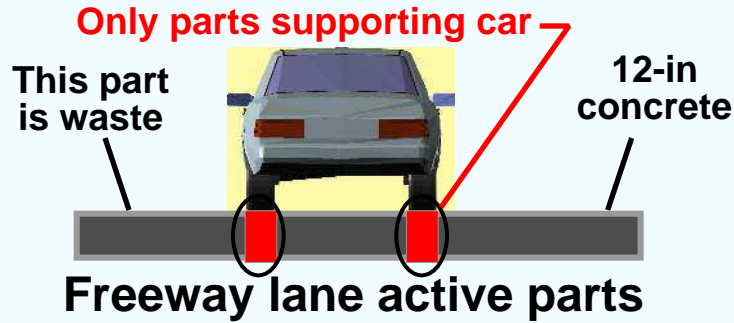

Low-cost, electrified, automated super-freeway

Real Solutions Now!

- Affordable **120-mph** shared *SuperWays*
 - *CarLiner*[™] passenger/car trains
 - *WhisperLiner*[™] passenger trains
 - *CargoLiner*[™] cargo trains
- Affordable *SuperWay* commutes
 - 85-mph *SuperWay* commuter *CarLiners*[™]
- ***Lower cost cargo transport than trucks!***
 - *CargoLiner*[™] **120-mph** non-stop module shipping

First services start within 42 months

***SuperWay* Major Advantages**

- **Far lower cost** - Use existent ROW – *Few new roads!*
 - *20 to 40%* of cost for other approaches
- **Far shorter time to service**
 - *30 to 40%* of time for other solutions
- **Local or state funding** – No **outside** funds needed
 - Revenue bonds + Some local / state funds
(**Systems can be self-sustaining and profitable**)
- **Future growth** – **Not available with other systems**

Can install NOW over any existent ROW

**Ultra-light
MegaWay
Solution**

Near-term at 20% of the cost!

**No wide swaths of land
needed**

One Base Design – *Many Options*

- Affordable **high-speed SuperWay**

20% of usual cost

- **WhisperLiner™** passenger trains
- **CarLiner™** passenger/car trains
- **CargoLiner™** cargo module trains

State funds – No wait for federal funds

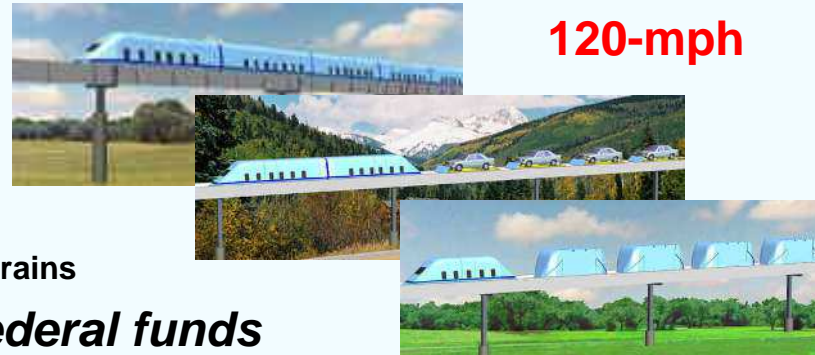

- Affordable **urban/commuter SuperWay**

20 – 22% of usual cost

- **MicroWay™** LRT & BRT alt.
- **MegaWay** commuter rail alt.

Local funds – No wait for federal funds

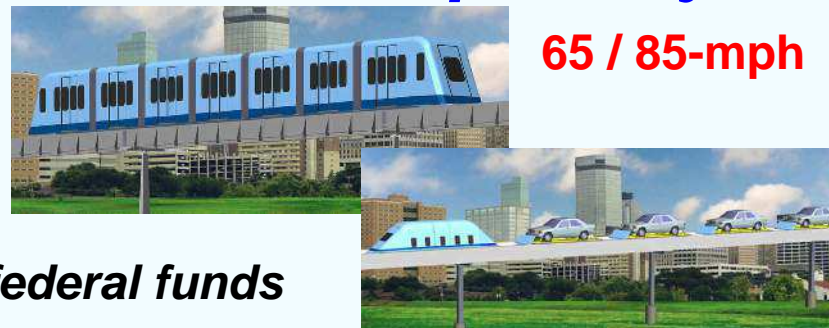

Install along current freeways

High-speed passenger & cargo lines

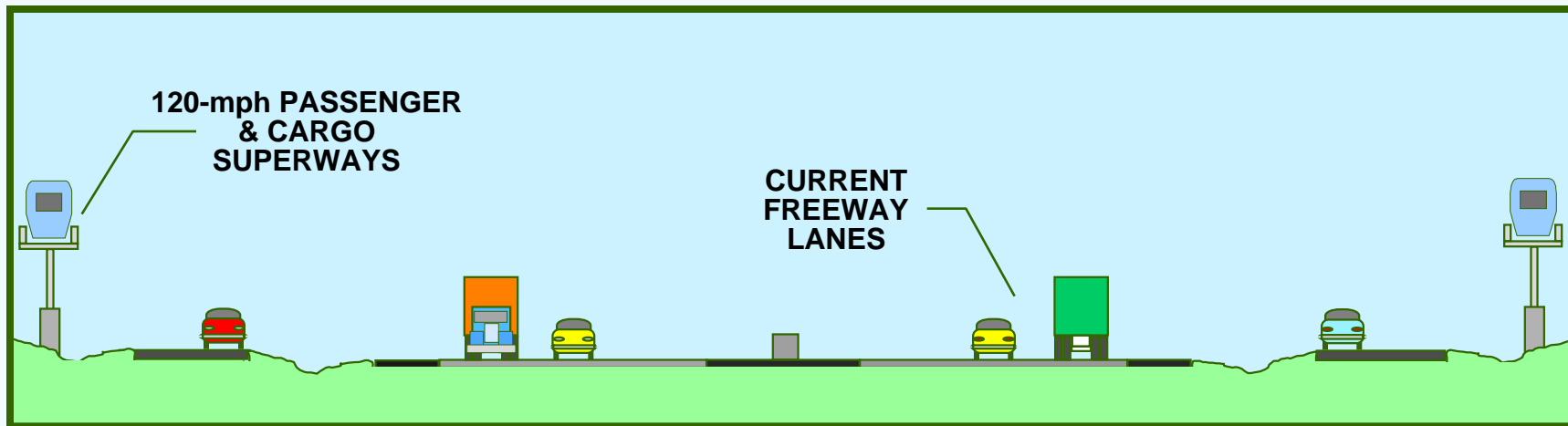

- Can use current highway right of way
- **Minimum traffic disruption for installation**
 - Rapid installation of factory-built parts
 - Concrete piers - *only on-site construction*

Superway 120-mph *WhisperLiner*TM

WhisperLiner – High-speed Inter-city Passenger Train Service

- Whisper-quiet smooth ride
- First-class airliner seating
- Airliner-type lavatories
- Grade-separated for safety
- Safe, derail-proof design
- All-weather service
- *Fast non-stop travel*



120-mph WhisperLiner
Superfreeway train along Interstate

- Service in 30 to 36 months
- **Clean, all-electric** operation
- Use Interstate right-of-way
- Ultra-low noise
- Train crew manual control
- **Affordable cost**

WhisperLiner – Passenger Coaches

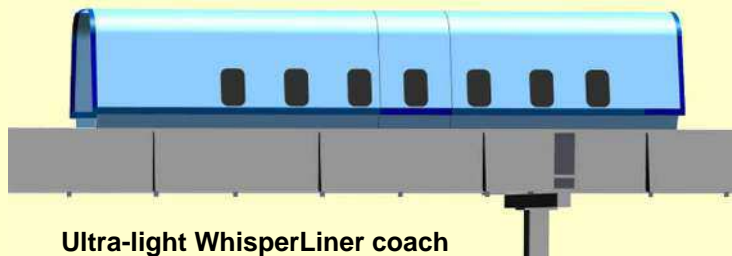

Ultra-light WhisperLiner coach

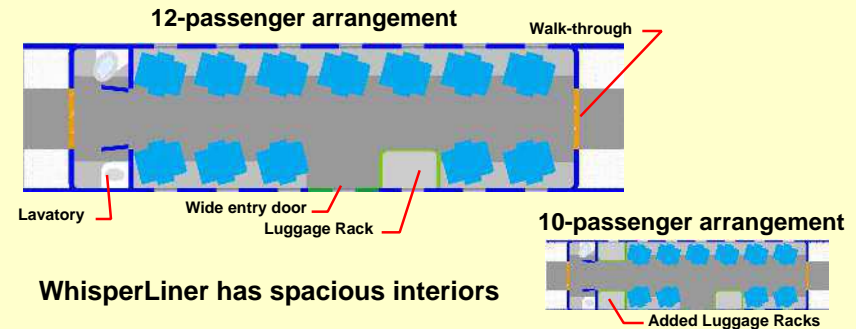

MegaWay 120-mph CarLiner™

CarLiner™ – Inter-city Passenger & Automobile Service

WhisperLiner service plus
– Take along your car!

- Park car as you board train
- Car available upon arrival
- Cars ride on car-ferries

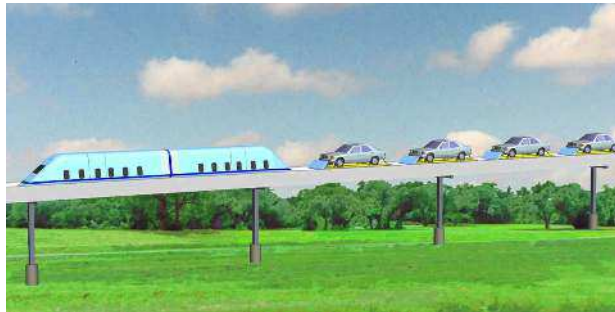

- Passengers park car on car ferries & then board coaches
- Passengers enter & drive their cars from ferries at destination

High-speed CarLiners share same *SuperWay*

CarLiner™ – Car-ferries

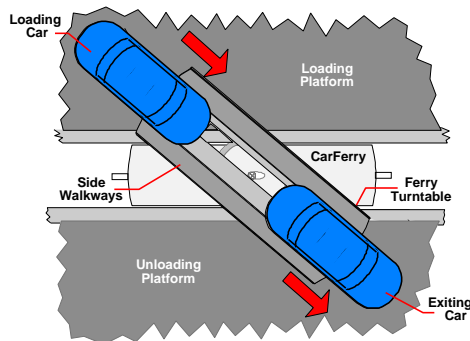

Rapid car loading & unloading at stations

Occupants walk to train coaches

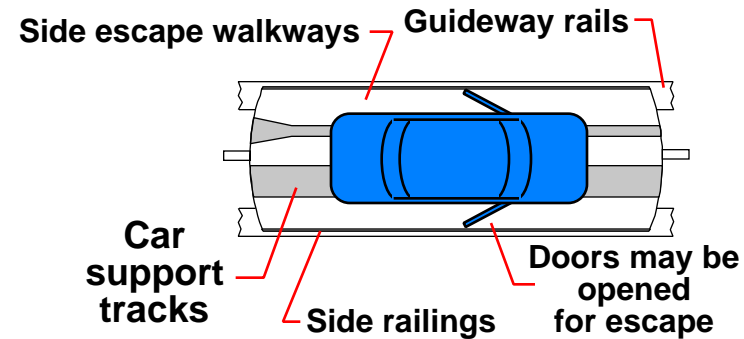

Sample *CarLiner*TM Station Arrangement

Short *Carliner* train shown to simplify illustration

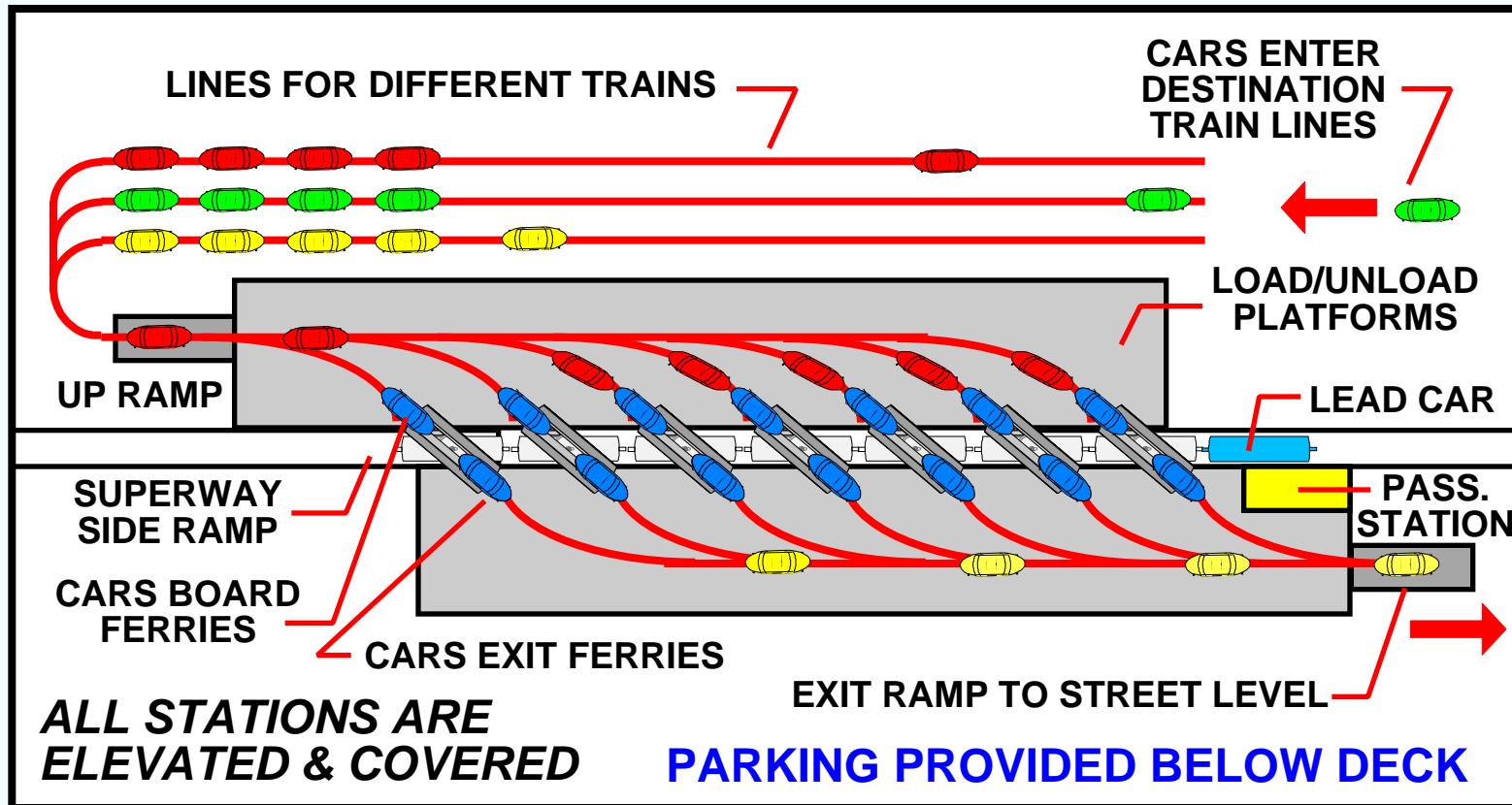

Drivers enter line for desired route or destination
(Trains may take different *MegaWay* routes)

MegaWay™ High-speed CargoLiner™

CargoLiner™ – Inter-city Containerized Cargo Service

- 120-mph cargo service
- Closed cargo containers
- Three tons / carrier
- Rapid container handling
- Truckable containers

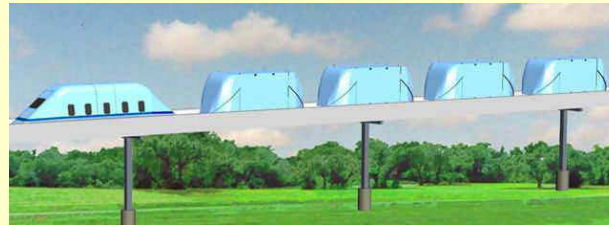

CargoLiners carry special closed containers

- Trains use same guideway as *WhisperLiners*
- Streamlined for low drag
- De-rail proof design
- Power for refrigeration
- Train crew manual control

CargoLiner™ Cargo Containers

- Upper lift points for loading
- Handle with forklift
- 1-1/2 and 3 ton containers
- Flat bed truck transport
- Closed containers

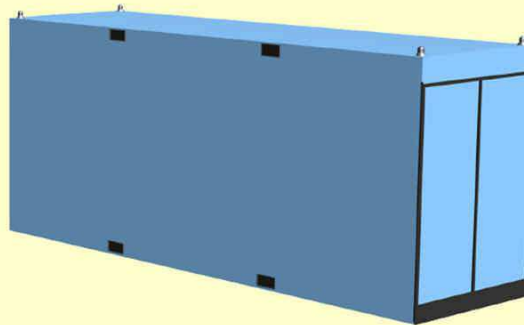

- Light weight
- Handle standard pallets
- Stackable
- Power connections
- Refrigeration available

***MegaWay* High-speed *Cargo* Capacity**

Greater Capacity than a Six Lane Freeway

- Cargo moves at **120-mph** speed – **Not 55-mph!**
- No traffic jams or delays – 24 hours per day
- Max cargo capacity calculation: (per direction)
 - Carriers spaced at 50-ft intervals = 105 vehicles/mi
 - 105 containers/mi x 120-mph x 3-tons = 37,800 tons/hr
 - 37,800 tons/hr x 24-hrs = **907,000 tons/day** = **22,000 trucks**
- Plenty of space for high-speed passenger service

Plus the freeways remain available!

85-mph Commuter *MegaWay* Ultralight Electric Transport

Near-term at 20 to 30% of commuter rail cost
Reduce demand for more urban freeways!

Ultralight Commuter *MegaWay* Service

Fast travel in train coach or in your own car at low cost

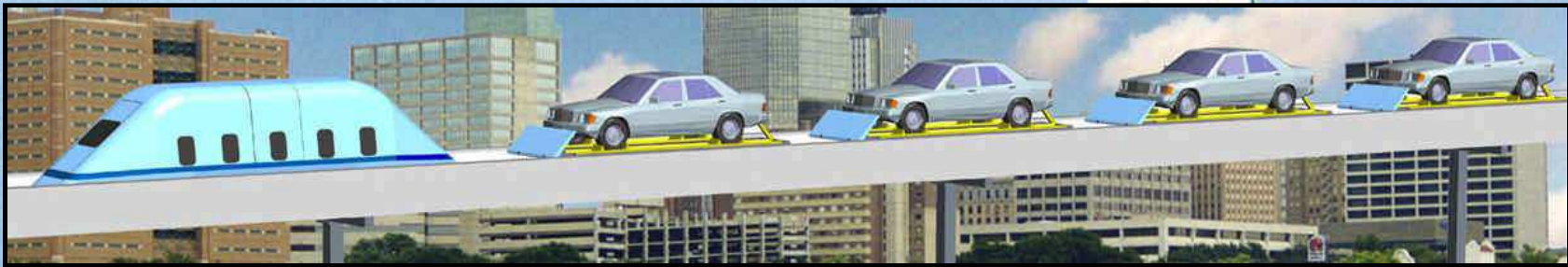

MegaWay CarFerry™ In-your-car Service

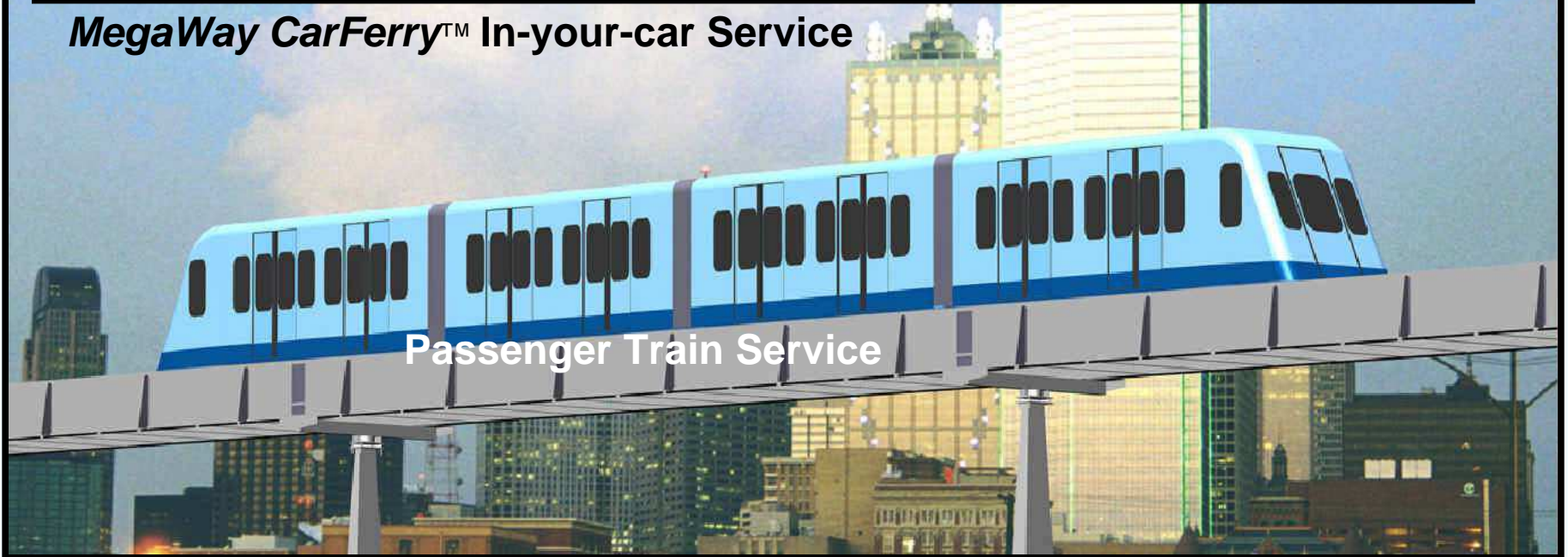

Passenger Train Service

Ultralight *MegaWay* commuter trains & *CarFerries* on elevated *Superway*
Both services can share same guideway!

MegaWay Phase II

- **Automate trains** - *Without throw-a-way*
 - Develop automated train control software
 - Demonstrate safe operation after failures

MegaWay Phase III

- High-speed *MegaWay* inter-city systems
 - Non-stop, Automated *MegaLiner*[™] small coach service
 - Automated *PersonLiner*[™] personal transport cars
 - Automated, single or dual cargo module transports
 - Automated *CarFerries*
- Urban *SuperWay* transport
 - *MegaWay* automated *CarFerries*
 - *MicroWay* automated *CarFerries*

Phase III 120-mph, Inter-city Services

U.S. Pat. 6,435,100



Carferries carry standard cars with driver and passengers inside

U.S. Patent 6,615,740

ROAM photos & graphics

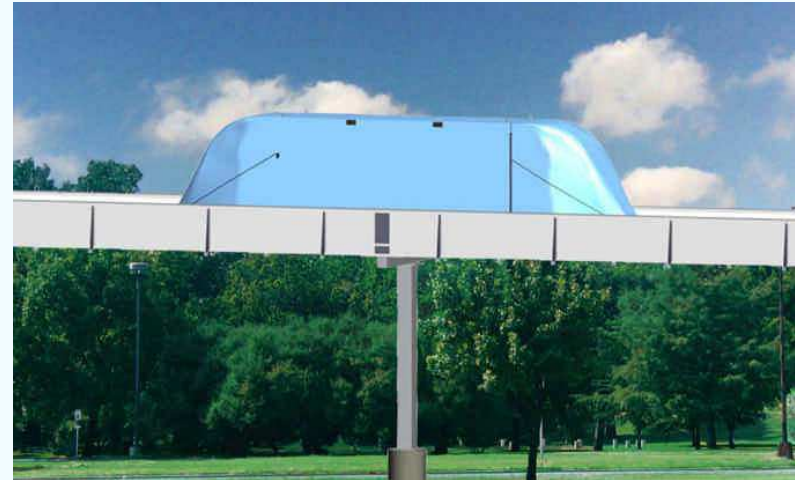

Automated cargo car on *SuperWay* moves modules at speeds up to 120-mph

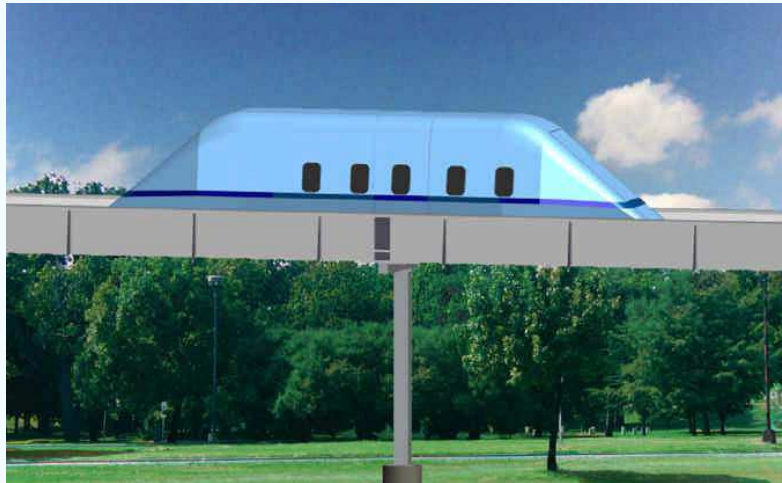

Automated, eight to nine-passenger *MegaLiner*™ non-stop, 120-mph, high-frequency, 24-hr group service

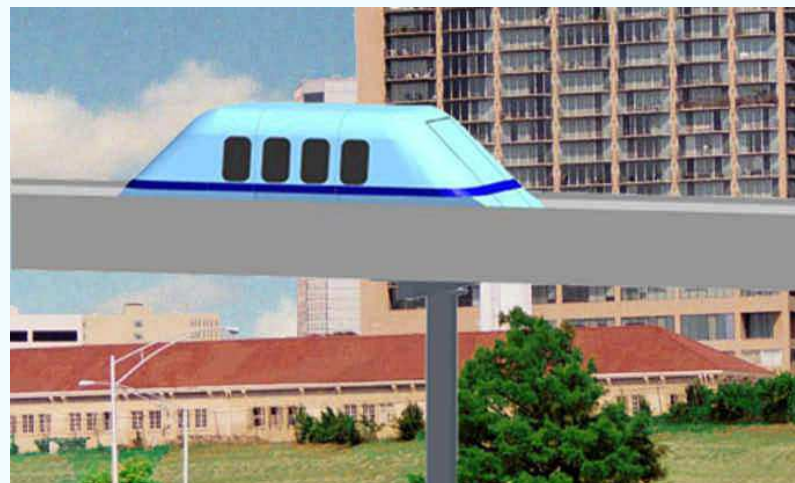

Four to six-passenger *PersonLiner*™ non-stop, 120-mph, on-call, 24-hr personal service

Needed Next Step

Conduct Demonstration

- **Prove it works at full 120-mph speed**
- **Develop TXDoT confidence**
- **Develop Executive & Legislative confidence**
- **Establish public confidence**
- **Confirm cost projections**
- **Sound basis for economic projections**
- ***Provide confidence for revenue bond buyers***

Possible Demo Options

- **Shortest test line – 3-miles – \$40M**

Single lane – One 120-mph train – One station
Accel to 120-mph & decelerate to stop

- **Longer test line – 5-miles – \$55M**

Single lane – One 120-mph train – One station
Accel to 120-mph, short cruise & decelerate to stop

- **Run back and forth for extensive testing**

Load & unload cars at station

Customer – ROAM effort to define location & funding

Technology Basis

Unique *green* solutions
using only innovative, yet **low-risk**
application of
off-the-shelf, **proven technology!**

SuperWay – Self-funding Alternate that Works

- Elevated steel *Superway* over any public right of way
 - Electrically-powered – Low pollution
 - Rubber-tired wheels in enclosed wheelway tubes
 - Silent service
 - All-weather service
 - Up and down hills
 - Low-cost
 - Small, separated wheelway tubes for low visual obstruction
- Little new right of way – Minimum land use
- *Serves ALL users – TAKES TRAFFIC OFF ROADS!*



Minimal sky blockage – No wide elevated conventional train shadows



Open-center *Superway* casts small shadow

U.S. Patent 6,837,167

Low risk – Current, proven technology!

SkyCoaches offer Safe Escape

Unaided escape for all (including wheelchairs) without rescue personnel

U.S. Patent 6,837,167



- Full-height escape doors in ends of coaches
- Open-mesh escape walkway between rails
- Covered electric bars



Upward view through walkway

Small, *Low Cost*, *Factory-built SuperWay*

Fast, bolt in place installation

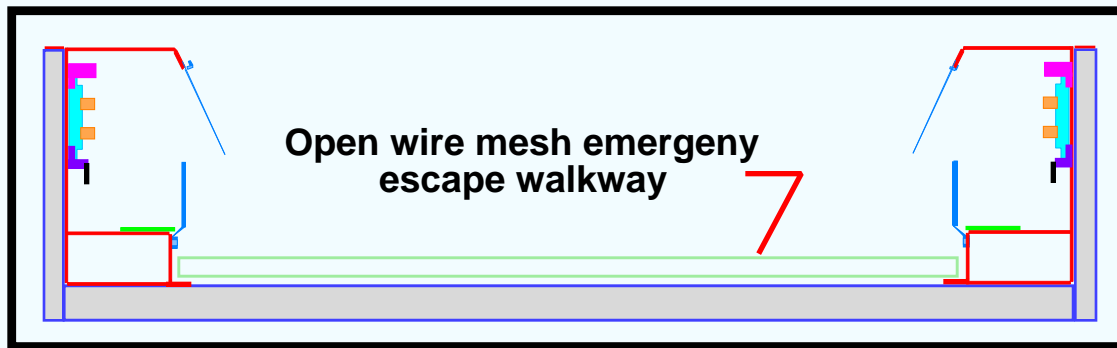

10.5-ft
wide by
40-inch
high
*MegaWay
Superway*

Ultralight *SuperWay* cross-section

Cost — 20% of elevated railway or freeway lane

- Uses highway/street right-of-way
- Mass-produced, factory-built sections – Fast on-site assembly
- No more land used & earth moving projects
- Light weight – Vehicles only 5% of typical railcar or truck weight

Unique *SuperWay* Features

Weather-proof wheelways

Essential Feature for Automated Operation

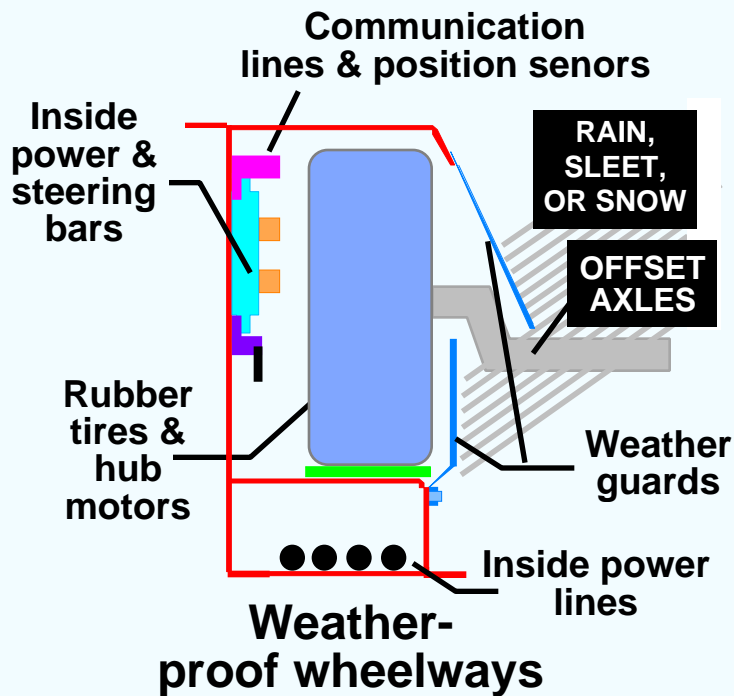

U.S. Pat. 6,039,135

Systems operate under all weather conditions

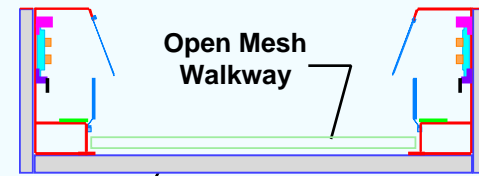

U.S. Pat. 6,837,167

Open *SuperWay* minimizes visual mass & light blockage to ground

***SuperWay* is elevated above surface activities**

17.5 FEET

GROUND SURFACE

Factory-built, Modular *SkyCoach*[™] Stations

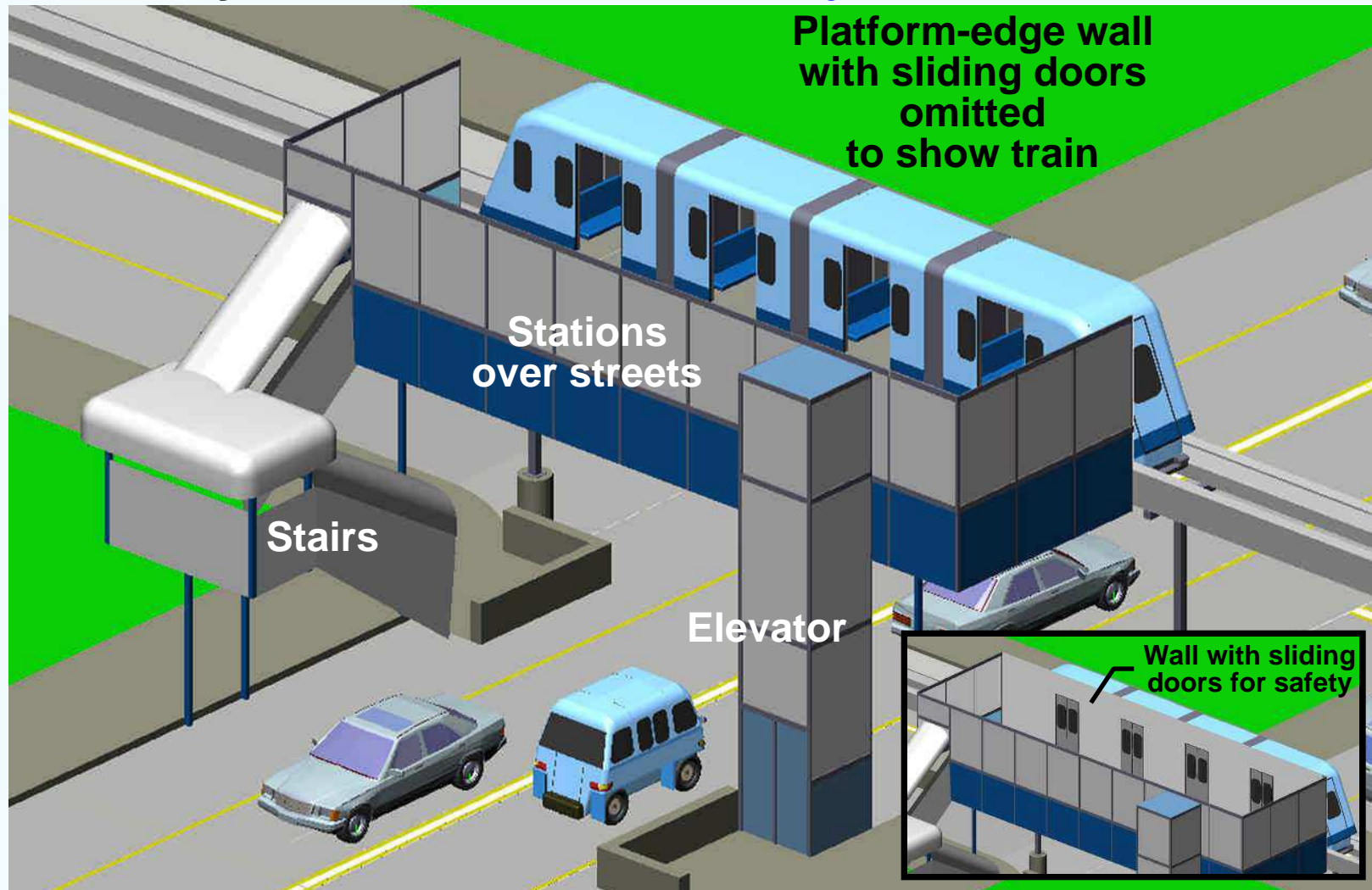

MicroWay[™] mass transit train at elevated, over-street *SkyCoach*[™] station

- Low-maintenance stainless-steel
- Low cost
- Minimum street impact

Prototype Test & Demo Vehicles

Road and *SuperWay* tested

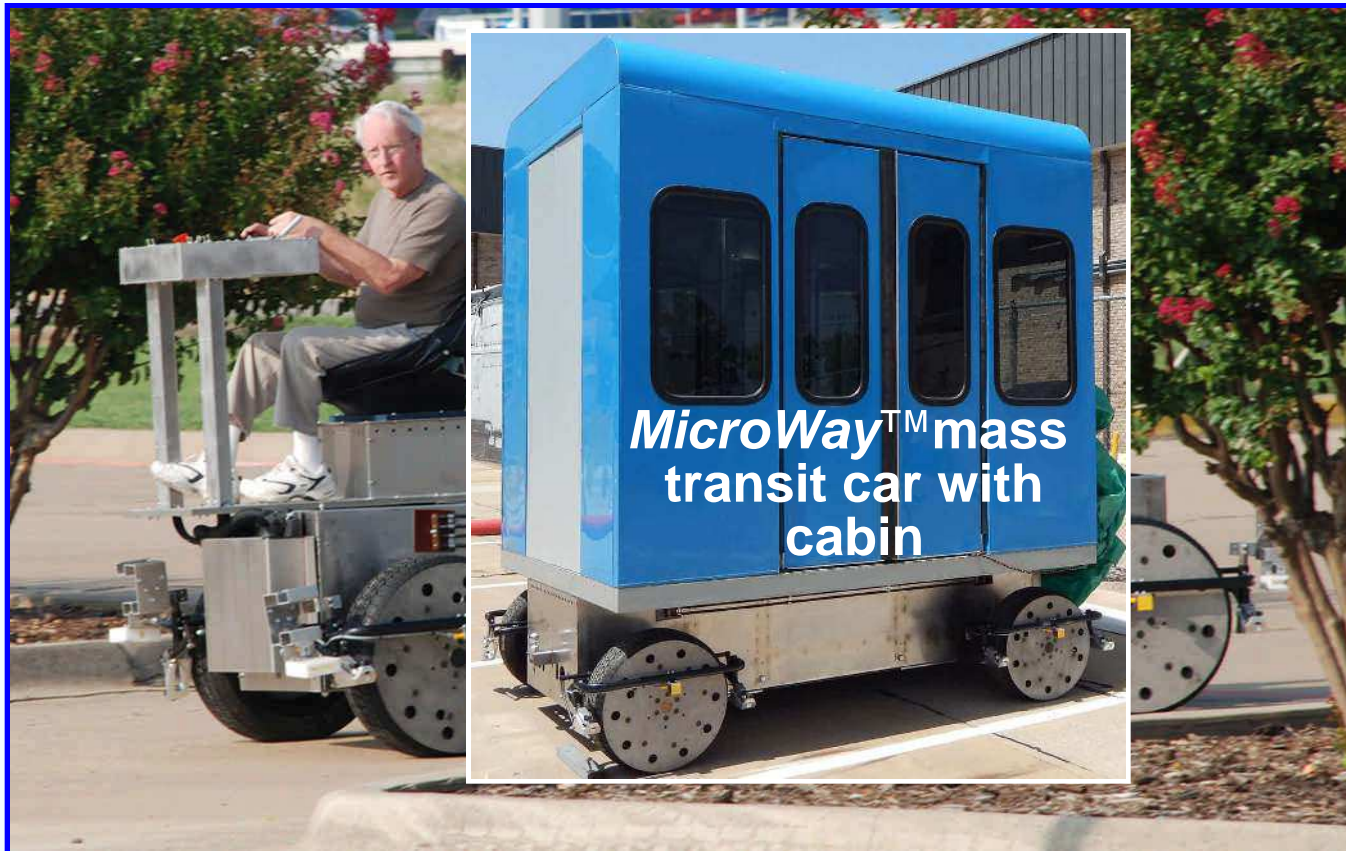

Hybrid dualmode car chassis unit in test & transit demo car
(Dualmode version operates both on *SuperWay* & streets)

Not just a “paper” system – It’s real and here!

Technology Summary

Unique, patented new combination of proven technology (8 patents)

Enclosed stainless-steel wheelways - US Pat. 6,039,135

- Simple welded steel factory fabrication
- Standard power rails

Flat-free tires – Current technology

Permanent-magnet electric motors

- Current commercial motor technology
- Electric motor wheels – Some electric cars

Car-based steering & switching

- Smooth non-contact electronic steering
- Switching – By cars as on conventional freeway!

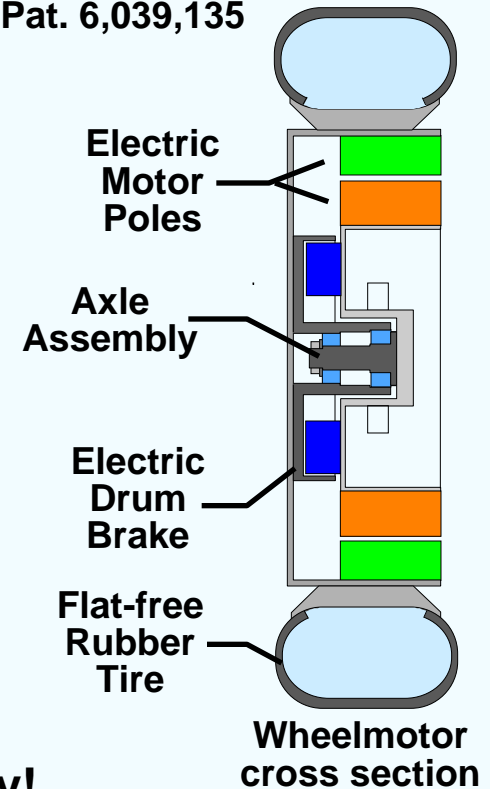

Only the combination & SuperWay are new!

MegaWay
Advantages Summary

Low-risk Solution

Revolutionary but only off-the-shelf, proven technology

- **First systems use manual control**
Control proven in transit and railroad systems
- **No exotic technology**
All technology proven in transit and auto systems*
- **State-wide system built in steps**
Initial line operation before large scale building
 - Determine public acceptance before large-scale commitment

* Future automated systems also employ proven aircraft technology

- **Low Cost**
- **Proven Tech**
- **Low Risk**

Environment-friendly

No adverse environmental impacts - Makes it better!

- **No Increased Air or Water Pollution – Electric power**
 - **Pollution reduced** by taking cars, trucks & buses from roads
- **No added traffic noise or freeway lights**
 - *Whisper-quiet* system makes **almost no noise**
 - No lights needed on superfreeways
- **No earth moving or drainage changes**
 - Elevated over existent rights-of-way
- **Minimum activity disruption**
 - **No blocked streets** or traffic stops • Night installation
- **Low visual cross-section – Minimal shadowing**
- ***No added land*** – Use existent road ROW

Conclusions

- **Far lower cost – *Easy to afford***
Revenue bonds for all or most of cost
- **Near-term – First service in 42 months**
No waiting for outside funds - go ahead now
- **Very low technical risk**
Only technology combination & superway are new
- **Very low environment impact**

Results

- **Cut big trucks – Cut traffic & road damage**
- **End freeway traffic jams**
- **120-mph, non-stop travel** in our own cars
- **120-mph, non-stop** public train service
- **Gas-generated** power for low air pollution
- **All-weather travel** – No snow & ice impacts
- **Avoid hundreds of billions for high-speed rail**

Nothing else offers anything close!



401 West Jim Wright Freeway, Suite113

Mail Address
P. O. Box 121728
Fort Worth, Texas 76121

(817) 738-9507

FAX (817) 367-2373

contact@roamtrans.com

www.roamtrans.com

Revolutionary, High-speed, Multi-user 21st Century Transport!

- *Unprecedented* level of service
- Low transportation user costs

**Near-term & affordable solution to
traffic & air pollution problems**

ROAM® Transport Systems, Fort Worth, Texas

SuperWay, MegaWay, CargoWay, MicroWay, CarLiner, CarFerry, SkyCoach, CargoLiner, WhisperLiner, MegaLiner, & PersonLiner are trademarks of ROAM Transport Systems

U.S. PATS. 6,039,135, 6,401,625, 6,435,100, 6,615,740, 6,742,458, 6,834,595, 6,837,167, & 7,926,425 B2

OTHER U.S. & INTERNATIONAL PATENTS PENDING